

# Nimma-L Series Laser

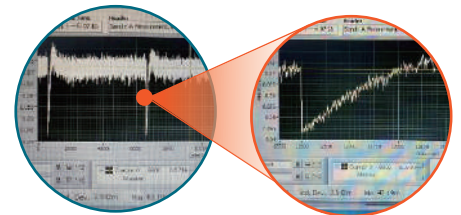

## Features

- Compact structure with a robust casing
- Function automatic phase matching
- Industrial design ensures long-term performance stability
- Flashlamp lifespan exceeds 70 million shots
- Operable via panel or software
- Integrated power supply and water cooling system



## Intelligent UV Pulsed Laser

The Nimma-L series laser is designed specifically for lidar, such as Ozone lidar, Raman lidar, etc. The harmonic generators are equipped with automatic phase matching function. In addition, it is also a good choice in the fields of pumping OPO, pumping dye laser, PLD and so on.

In terms of engineering, the lifetime of flashlamp is more than 70 million shots, greatly reducing the cost of maintenance. The UV harmonics use constant temperature technology and have a short warming up time, which reduced the rising time of energy at cyclic operation mode.

## Applications

- Ozone LIDAR
- Raman LIDAR
- Pumping OPO
- PLD
- Pumping dye laser



LIDAR



PLD

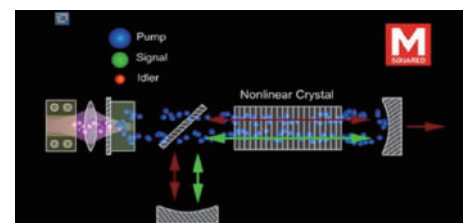

Pumping OPO



Beamtech Optronics Co.,Ltd.  
<http://www.beamtech-laser.com>  
Head Office  
15566 Buena Vista Ave, White Rock, BC V4B 1Z2, Canada  
phone: 604-960-1429  
Email: beamtech@shaw.ca

Manufacture&Technology Center  
Building B, Hongfu Technology Park,  
Changping Beijing, China 102209  
Tel: 010-84945016/17/18/19  
Fax: 010-84945020



# Specifications

Models		Nimma-L-532	Nimma-L-355	Nimma-L-266
Repetition Rate		1-10Hz	1-10Hz	1-10Hz
Wavelength		532nm	355nm	266nm
Pulse Energy:		480mJ	200mJ	80mJ
Energy Stability <sup>1</sup> (RMS)		≤2%	≤4%	≤4%
Pulse Width <sup>2</sup>		≤8ns	≤8ns	≤8ns
Divergence <sup>3</sup>		≤0.6mrad	≤0.6mrad	≤0.6mrad
Pointing Stability		≤30mrad	≤30mrad	≤30mrad
Jitter <sup>4</sup> (RMS)		≤0.5ns	≤0.5ns	≤0.5ns
Beam Diameter <sup>5</sup>		9mm±1mm	9mm±1mm	9mm±1mm
Polarization		Linear(Vertical)	Linear(Horizontal)	Linear(Horizontal)
Cooling		Air to water		
Electrical Service		220V-50/60Hz-10A		
Power Consumption		2000W		
Cable Length	Control Line	3m		
	Power Line	1.8m		
	Umbilical Line	3m		

1. Dev. to average (shot to shot for 99% of pulses).  
 2. Full width half max (FWHM).  
 3. Full angle at 1/e<sup>2</sup> of the peak.  
 4. With respect to external trigger.  
 5. Measured at the laser output.

# Dimensions

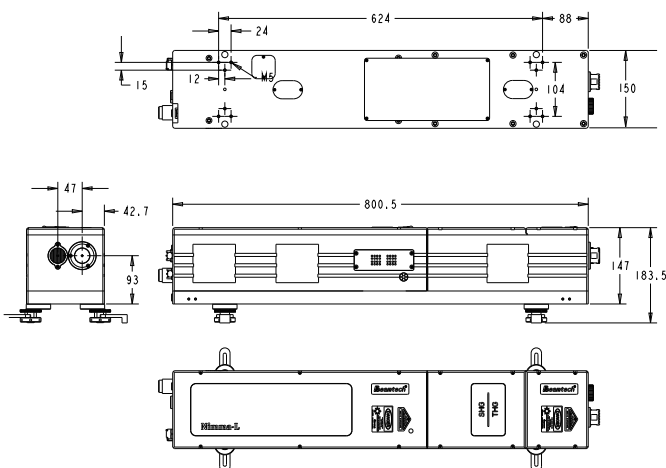

Laser head

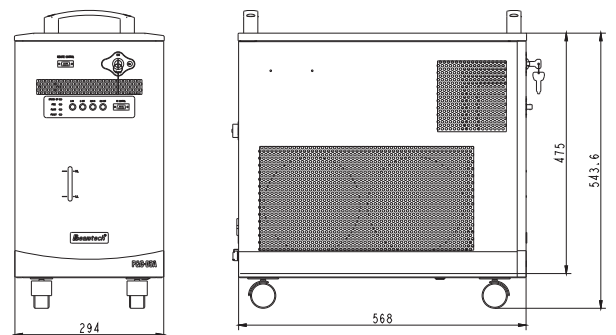

Power Supply & Cooling System